



# Battery-Box LV Flex Lite Operating Manual

V1.0



Shenzhen BYD Electronic Co., LTD



Be Connect



## Legal Provisions

All the information in this document is the property of Shenzhen BYD Electronic Co., LTD. No part of this document could be reproduced in any way for business use. Internal use is allowed.

Shenzhen BYD Electronic Co., LTD makes no representations or warranties express or implied, with respect to this document or any of the equipment and/or software it may describe, including (with no limitation) any implied warranties of utility, merchantability, or fitness for any particular purpose. All such representations or warranties are expressly disclaimed. Neither Shenzhen BYD Electronic Co., LTD nor its distributors or dealers shall be liable for any indirect, incidental, or consequential damages under any circumstances.

The exclusion of implied warranties may not apply in all cases under some statutes, and thus the above exclusion may not apply.

This document does not replace and is not intended to replace any local, state, provincial, federal, or national laws, regulations, or codes applicable to the installation, electrical safety, and use of the battery system. Shenzhen BYD Electronic Co., LTD assumes no responsibility for the compliance or noncompliance with such laws or codes in connection with the installation of the battery system.

Specifications are subject to change without notice. Every effort has been made to make this document complete, accurate, and up-to-date. However, Shenzhen BYD Electronic Co., LTD may need to make some improvements under certain circumstances without advance notice. Shenzhen BYD Electronic Co., LTD shall not be responsible for any loss caused by this document, including, but not limited to, omissions errors, typographical errors, arithmetical errors, or listing errors in this document.

All trademarks are recognized.

### Limited Warranty

You can download the latest Limited Warranty from the Internet at [www.bydbatterybox.com](http://www.bydbatterybox.com).

### Shenzhen BYD Electronic Co., LTD

No.1, Yan'an Road Kuichong, Dapeng, Shenzhen, Guangdong Province, 518118 , P.R. China

# Content

Legal Provisions .....	1
1. Information on this Document .....	4
1.1. Validity .....	4
1.2. Target Group .....	4
1.3. Content and Structure of this Document.....	4
1.4. Declaration of Conformity .....	4
1.5. Levels of Warning Messages.....	4
1.6. Symbols in the Document.....	5
1.7. Designation in the Document.....	5
2. Safety.....	6
2.1. Intended Use .....	6
2.2. IMPORTANT SAFETY INSTRUCTIONS.....	6
2.2.1. Battery Module Leakage .....	6
2.2.2. Firefighting Measures.....	6
2.2.3. Battery Modules Handling and Storage Guide .....	7
2.2.4. Warning of Overvoltages.....	7
2.2.5. Caution of Weight.....	8
2.2.6. Notice of Property Damage .....	8
3. Scope of Delivery.....	9
4. Battery System Overview.....	10
4.1. Battery System Description .....	10
4.2. Interface.....	10
4.3. Symbols on the System .....	11
4.4. LED Signals.....	12
5. Installation.....	13
5.1. Requirements for Installation .....	13
5.1.1. Requirements for Installation Location .....	13
5.1.2. Tools.....	13
5.1.3. Safety Gear .....	14
5.1.4. Additionally Required Installation Material .....	14
5.2. Installation.....	14

---

5.2.1.	Installation without Any Rack or Cabinet.....	14
5.2.2.	Installed in a Rack or Cabinet .....	16
6.	Electrical Connection .....	17
6.1.	Overview of the Connection Area .....	17
6.2.	Connection Diagram .....	18
6.3.	Connecting the PE.....	18
6.4.	Data Cable Connection.....	19
6.4.1.	Data Cable Connection between Inverter and BMU .....	19
6.4.2.	Data Cable Connection between BMU and a battery module .....	20
6.4.3.	Data Cable Connection between battery modules .....	20
6.4.4.	Data Cable Connection between BMU and Router .....	21
6.5.	DC Connection .....	21
7.	Commissioning .....	23
7.1.	Switch on the Battery System.....	23
7.2.	Configure the Battery System.....	23
7.3.	Switch on and Commission the Inverter .....	26
8.	Operation .....	27
8.1.	Switch on the Battery System.....	27
8.2.	Switch off the Battery System.....	28
9.	Decommissioning.....	29
10.	Extension .....	30
11.	Troubleshooting .....	31
11.1.	Battery System Behavior under Fault Conditions.....	31
11.2.	LED Light Designation for Errors.....	31
12.	Maintenance and Storage .....	33
13.	Disposal of the Battery System .....	34
14.	Technical Parameters .....	35
15.	Contact Information.....	36
	Appendix Data Cable Connection Instruction with Inverters.....	37

# 1. Information on this Document

## 1.1. Validity

This document is valid for the Battery-Box LV Flex Lite.

## 1.2. Target Group

The instructions in this document may only be performed by qualified persons who must have the following skills:

- Knowledge of how batteries work and are operated
- Knowledge of how an inverter works and is operated
- Knowledge of, and adherence to the locally applicable connection requirements, standards, and directives
- Knowledge of, and adherence to this document and the associated system documentation, including all safety instructions
- Training in dealing with the hazards associated with the installation and operation of electrical equipment and batteries
- Training in the installation and commissioning of electrical equipment

Failure to do so will make any manufacturer's warranty, guarantee or liability null, and void unless you can prove that the damage was not due to non-compliance.

## 1.3. Content and Structure of this Document

This document contains safety information and instructions, scope of delivery, battery system overview, installation, electrical connection, commissioning, operation, decommissioning, extension, troubleshooting, maintenance and storage, disposal of the battery system, technical parameters and contact information. Please finish reading this document before taking any actions on the battery system.

## 1.4. Declaration of Conformity

The battery system described in this document complies with the applicable European directives. The certificate is available in the download area at [www.bydbatterybox.com](http://www.bydbatterybox.com).

## 1.5. Levels of Warning Messages

The following levels of warning messages may occur when handling the battery system.



Indicates a hazardous situation which, if not avoided, will result in death or serious injury.



Indicates a hazardous situation which, if not avoided, could result in minor or moderate injury.



Indicates a hazardous situation which, if not avoided, could result in minor or moderate injury.

### NOTICE

Indicates a situation which, if not avoided, can result in property damage.

## 1.6. Symbols in the Document



Sections describing activities to be performed by qualified persons only.

## 1.7. Designation in the Document

Designation in this document	Complete designation
Battery System	Battery-Box LV Flex Lite
BIC	Battery Information Collector
BMS	Battery Management System
BMU	Battery-Box Premium LV BMU
BYD	Shenzhen BYD Electronic Co., LTD
SOC	State of Charge

## 2. Safety

### 2.1. Intended Use

The battery system is for residential and works with a photovoltaic system. It is a 48V Li-ion battery storage system, with the control module on itself. It could be operated in on-grid and off-grid modes with compatible inverters.

The battery system could be connected to the Internet through network cable for maintenance and firmware updating.

The battery system must only be used as stationary equipment.

The battery system is suitable for indoor use under the conditions mentioned in Section 5.1. If the battery is protected quite well, and the overall system (together with the additional rack or cabinet outside it) could reach IP55, the battery system could be used for outdoor.

The battery system must only be operated in connection with a compatible inverter. The list (BYD Battery-Box LV Flex Lite Configuration List) of these inverters could be found at [www.bydbatterybox.com](http://www.bydbatterybox.com).

The battery system is not suitable for supplying life-sustaining medical devices. Please ensure that no personal injury would lead due to the power outage of the battery system.

Alterations to the battery system, e.g., changes or modifications are not allowed unless the written permission of BYD is achieved. Unauthorized alterations will void the guarantee and warranty claims. BYD shall not be held liable for any damage caused by such changes.

The type label should always be attached to the battery system.

### 2.2. IMPORTANT SAFETY INSTRUCTIONS

The battery system has been designed and tested in accordance with international safety requirements. However, in order to prevent personal injury and property damage and ensure long-term operation of the battery system, please do read this section carefully and observe all safety information at all times.

#### 2.2.1. Battery Module Leakage

If the battery modules leak electrolytes, contact with the leaking liquid or gas should be avoided. The electrolyte is corrosive, and the contact may cause skin irritation and chemical burns. If one is exposed to the leaked substance, do these actions:

**Inhalation:** Evacuate the contaminated area, and seek medical help immediately.

**Eye contact:** Rinse eyes with flowing water for 15 minutes and seek medical help immediately.

**Skin contact:** Wash the affected area thoroughly with soap and water and seek medical help immediately.

**Ingestion:** Induce vomiting and seek medical help immediately.

#### 2.2.2. Firefighting Measures

The battery modules may catch fire when it is put into the fire. In case of a fire, please make sure that an ABC or carbon dioxide extinguisher is nearby. Water cannot be used to extinguish the fire.

Full protective clothing and self-contained breathing apparatus are required for the firefighters to extinguish the fire.

### 2.2.3. Battery Modules Handling and Storage Guide

- The battery modules and its components should be protected from damage when transporting and handling.
- Do not impact, pull, drag, or step on the battery modules.
- Do not insert unrelated objects into any part of the battery modules.
- Do not throw the battery module into a fire.
- Do not soak the battery modules in water or seawater.
- Do not expose to strong oxidizers.
- Do not short circuit the battery modules.
- The battery modules cannot be stored at high temperatures (more than 50° C).
- The battery modules cannot be stored directly under the sun.
- The battery modules cannot be stored in a high humidity environment.
- Do not use the battery modules if it is defective, or appears cracked, broken or otherwise damaged, or fails to operate.
- Do not attempt to open, disassemble, repair, tamper with, or modify the battery modules. The battery modules are not user-serviceable.
- Do not use cleaning solvents to clean the battery modules.

### 2.2.4. Warning of Overvoltages



#### **Danger to life due to electric shock in case of Overvoltages and if surge protection is missing**

Overvoltages (e. g. in the event of a flash of lightning) can be further conducted into the building and to other connected devices in the same network via the network cables or other data cables if there is no surge protection. Touching live parts and cables results in death or lethal injuries due to electric shock.

- Ensure that all devices in the same network and the inverter are integrated into the existing surge protection.
- When laying the network cables or other data cables outdoors, it must be ensured that a suitable surge protection device is provided at the transition point of the cable from the system or the inverter outdoors to the inside of a building.

### 2.2.5. Caution of Weight



#### **Risk of injury due to weight of the battery module**

Injuries may result if the battery module is lifted incorrectly or dropped while being transported or installed.

- Transport and lift the battery module carefully. Take the weight of the battery module into account.
- Wear suitable personal protective equipment for all work on the battery system.

### 2.2.6. Notice of Property Damage

#### **NOTICE**

#### **Damage to the battery system due to under voltages**

- If the battery system doesn't start at all, please contact BYD local after-sales service within 48 hours. Otherwise, the battery could be permanently damaged.

### 3. Scope of Delivery

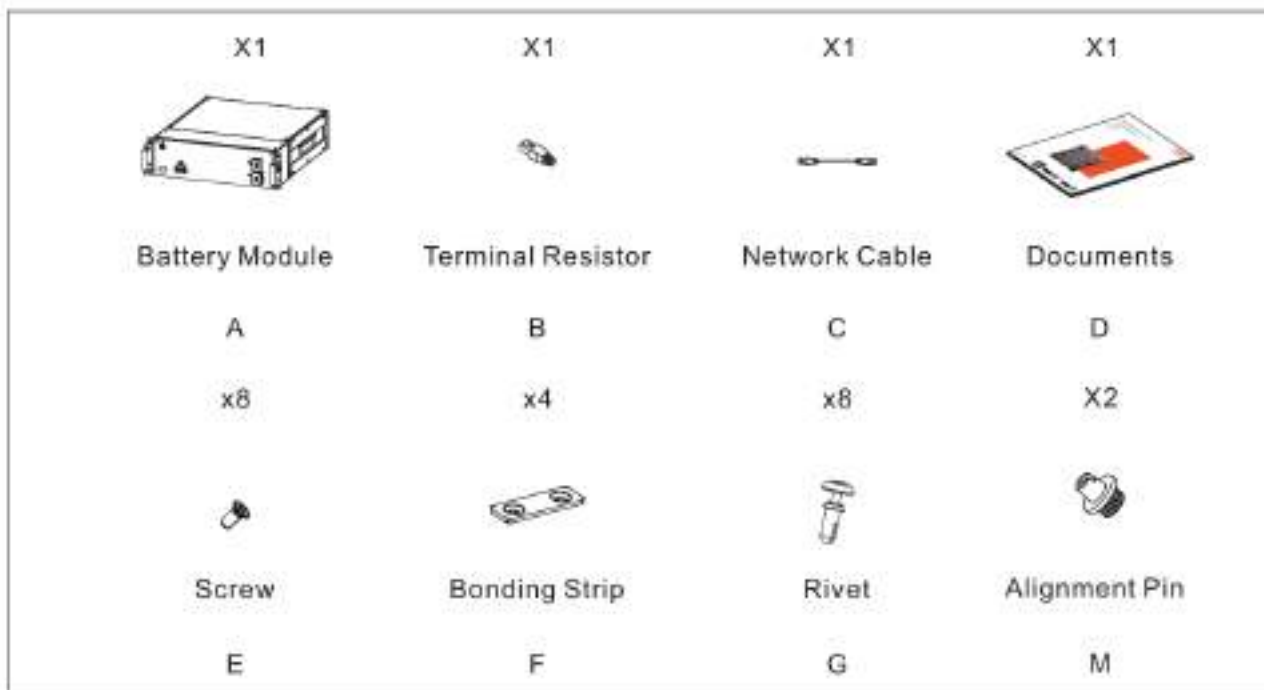

A	Battery Module
B	Terminal Resistor
C	Network Cable
D	Documents
E	Screw
F	Bonding Strip
G	Rivet
M	Alignment Pin

## 4. Battery System Overview

### 4.1. Battery System Description

The Battery-Box LV Flex Lite used as a connected battery for the intermediate storage of excess PV energy in an inverter system.

It works together with Battery-Box Premium LV BMU or Battery-Box Premium LV BMU - IP55 (BMU). The parameters and instruction of BMU could be read on our websites. The battery system could support the backup function of inverters and is compatible with both 1 and 3 phase inverters.

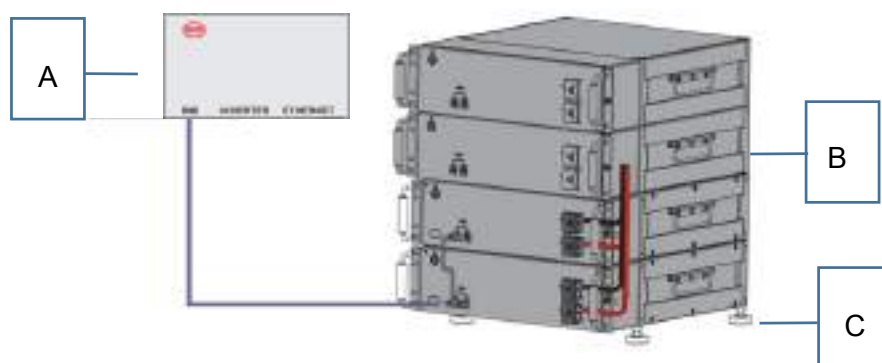

A	BMU
B	Battery Module
C	Legs (not in the scope of delivery)

Without a rack, maximum four battery modules could be installed in one tower.

Maximum 64 modules could be connected in parallel.

### 4.2. Interface

#### Be Connect

Be Connect is an app for Android and iOS system devices. You can download it from Google Play or App Store. Search Be Connect or scan the QR code on this document cover.

With Be Connect, you can update the firmware, configure and read the information of the battery system, etc.

#### Be Connect Plus











Be Connect Plus is a PC app. You can download from our website (<https://www.bydbatterybox.com/downloads>).



With Be Connect Plus, you can configure and diagnose the battery system, read the general battery information, update the firmware, etc.

### Be Connect Monitoring



BMU is equipped with an Ethernet interface as a standard. When your battery system accesses to the Internet, it will join our Be Connect Monitoring, which is a platform for BYD to provide remote service to customers. It can diagnose your battery system, and update the firmware. It is highly recommended you to access your system to the Internet.

### 4.3. Symbols on the System

Symbol	Explanation
	Observe the documents Observe all documents supplied with the system.
	Grounding conductor This symbol indicates the position for connecting a grounding conductor.
	WEEE designation Do not dispose of the system together with the household waste but in accordance with the disposal regulations for electronic waste applicable at the installation site.
	CE marking The system complies with the requirements of the applicable EU directives.
	This side up.
	Handle with care.
	Keep dry.
	Keep the battery modules away from open flame or ignition sources.
	Beware of electrical voltage.
	Beware of a danger zone This symbol indicates that the system must be additionally grounded if additional grounding or equipotential bonding is required at the installation site.

	Keep the battery modules away from children.
	RCM (Regulatory Compliance Mark), a brief guide to Electrical equipment approvals in Australia
	Do not short circuit.

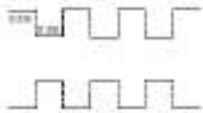
### 4.4. LED Signals

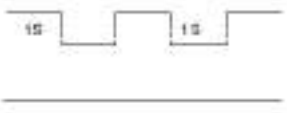
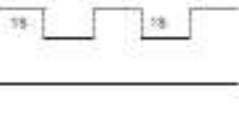
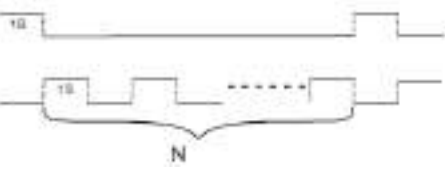
Flashing white and blue alternatively	<p>White <input type="radio"/> ON <input type="radio"/> OFF</p> <p>Blue <input checked="" type="radio"/> ON <input type="radio"/> OFF</p> 	The battery system is initiating.
Static white	<p>White <input type="radio"/> ON <input type="radio"/> OFF</p> <p>Blue <input checked="" type="radio"/> ON <input type="radio"/> OFF</p> 	Idle (the battery system is neither charging nor discharging).
Flashing white slowly	<p>White <input type="radio"/> ON <input type="radio"/> OFF</p> <p>Blue <input checked="" type="radio"/> ON <input type="radio"/> OFF</p> 	The battery system is charging.
Flashing white quickly	<p>White <input type="radio"/> ON <input type="radio"/> OFF</p> <p>Blue <input checked="" type="radio"/> ON <input type="radio"/> OFF</p> 	The battery system is discharging.
Flashing white and glowing blue	<p>White <input type="radio"/> ON <input type="radio"/> OFF</p> <p>Blue <input checked="" type="radio"/> ON <input type="radio"/> OFF</p> 	The battery system is discharging, and the SOC is below 15%.
Flashing white and blue	<p>White <input type="radio"/> ON <input type="radio"/> OFF</p> <p>Blue <input checked="" type="radio"/> ON <input type="radio"/> OFF</p> 	An event message has occurred (refer to the Service Guideline and Checklist for further details)

## 5. Installation

### 5.1. Requirements for Installation

#### 5.1.1. Requirements for Installation Location

- a) A solid support surface must be available (e.g., concrete or masonry).
- b) The installation location must be inaccessible to children.
- c) The installation location must be suitable for the weight and dimensions of the battery system.
- d) The installation location must not be exposed to direct solar irradiation.
- e) The installation location must not be close to heat source.
- f) The altitude of the installation location should be less than 2000m.
- g) The ambient temperature should be between -10°C and +50°C.
- h) The ambient humidity should be between 5-95%.
- i) Do not install the battery in a closed place where the ventilation is not available.
- j) Follow the minimum clearance requirements as shown in the drawing below.

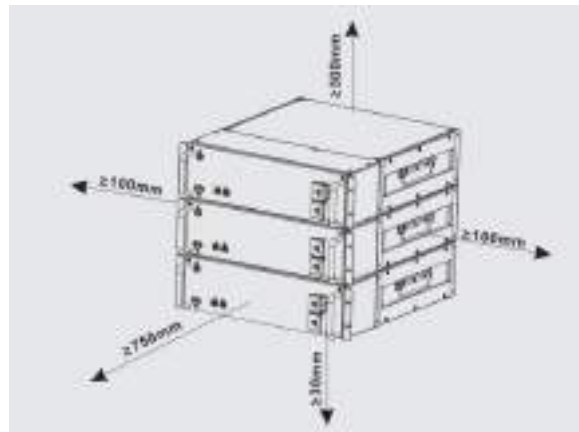

#### 5.1.2. Tools

The tools in the following table could be needed during the installation.



### 5.1.3. Safety Gear

Wear the following safety gear when dealing with the battery system.



Safety shoes

### 5.1.4. Additionally Required Installation Material

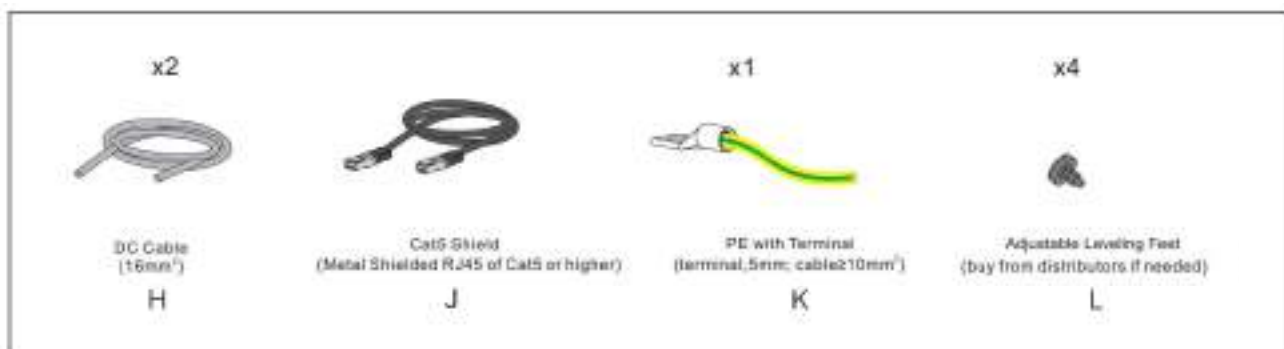

## 5.2. Installation

### ⚠ QUALIFIED PERSON

The LV Flex Lite modules could be installed without any rack or cabinet, or with a rack or cabinet. The modules could be horizontally or vertically after installation.

### ⚠ CAUTION

#### Risk of injury due to weight of the battery module

Injuries may result if the battery module is lifted incorrectly or dropped while being transported or installed.

- Transport and lift the battery module carefully. Take the weight of the battery module into account.
- Wear suitable personal protective equipment for all work on the battery system.

### 5.2.1. Installation without Any Rack or Cabinet

**Additionally required mounting material (not included in the scope of delivery):**

Four adjustable leveling feet for the modules. You can buy them from distributors if you want to install in this way.

**Procedure:**

1. Take the module out of the package.
2. Install four adjustable leveling feet.



3. Install the four alignment pins.

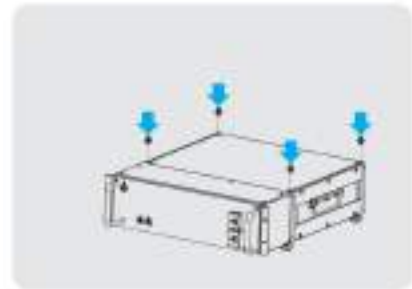

4. Put another module on top of the previous module.



5. Install the bonding strips to fix the modules together.  
(torque,  $3\pm 0.5$  N·m)

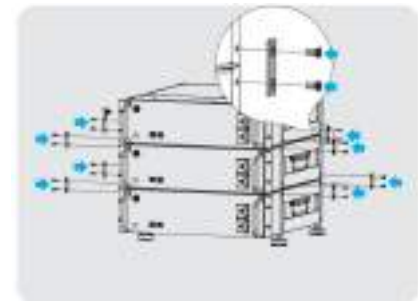

### 5.2.2. Installed in a Rack or Cabinet

**Additionally required mounting material (not included in the scope of delivery):**

Rack or cabinet and related screws.

**Procedure:**

1. Put the modules into the dedicated positions.
2. Insert the screws and fasten the modules to the rack or cabinet.

## 6. Electrical Connection

### 6.1. Overview of the Connection Area

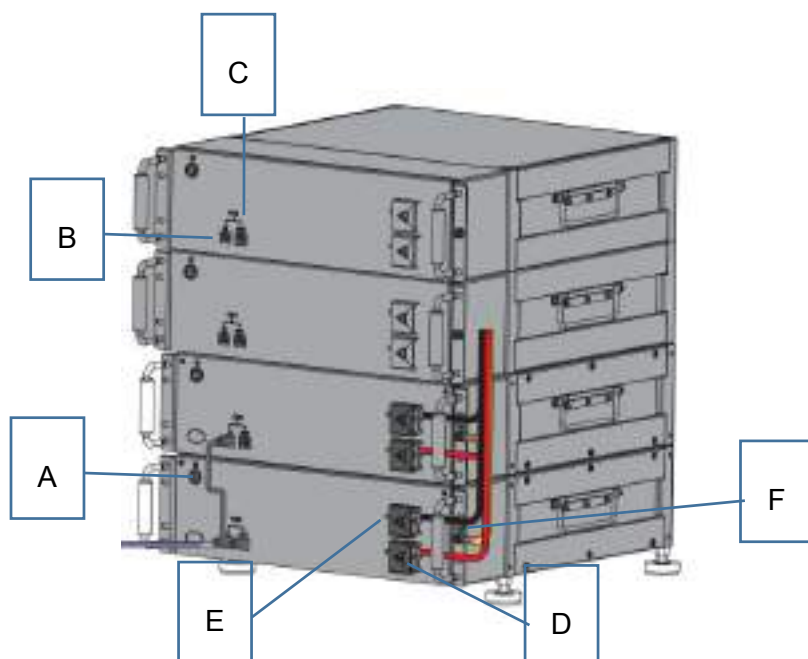

A		LED Button
B	IN	Communication Port
C	OUT	Communication Port
D	P+	Power Cable Connection Point (P+)
E	P-	Power Cable Connection Point (P+)
F		Grounding Point

## 6.2. Connection Diagram

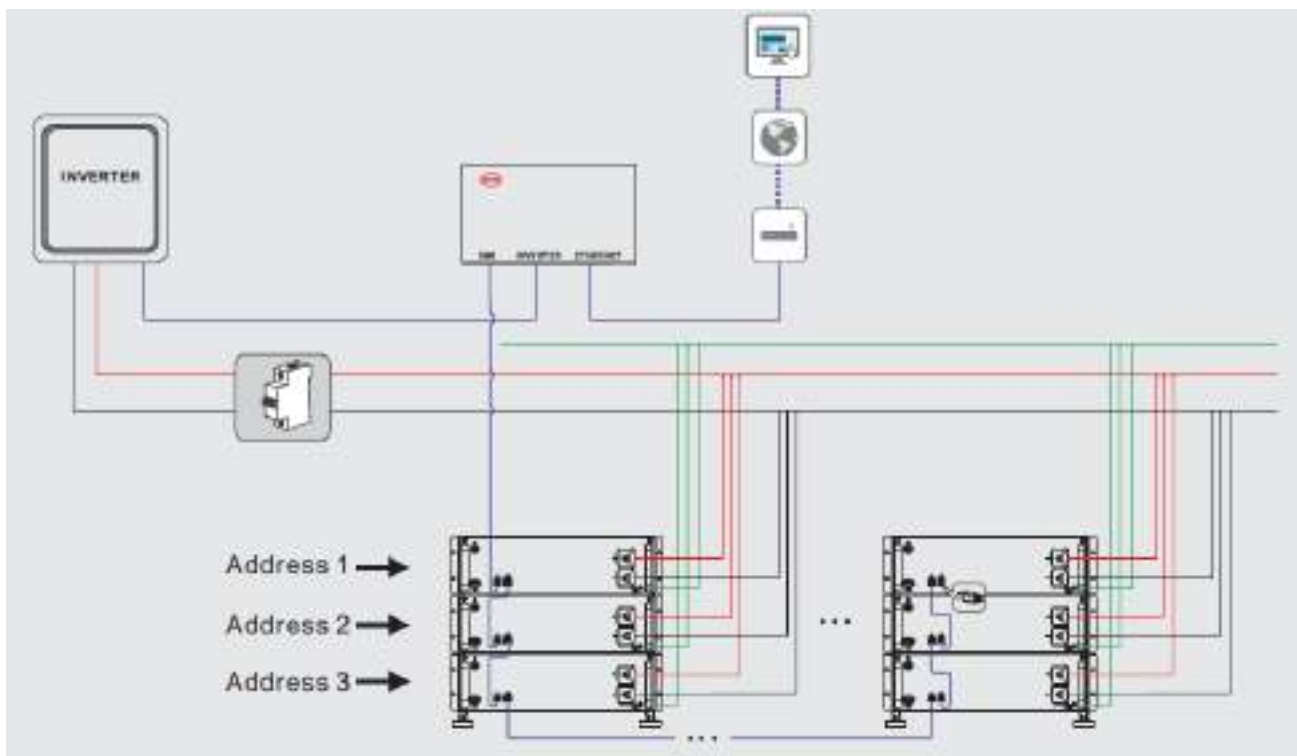

The connection to Ethernet cable is recommended, not compulsory.

## 6.3. Connecting the PE

### ⚠ QUALIFIED PERSON

Additionally required mounting material (not included in the scope of delivery):

PE with Terminal

#### PE and Terminal Requirement

- Terminal, 5mm.
- Minimum terminal cross-section: 10 mm<sup>2</sup>
- The cross-section of the grounding terminal must comply with the locally applicable standards and directives
- PE Material: Copper wire

#### Procedure:

- Make sure the modules are switched off.
- Take out the grounding screw, and get the PE conductor through it.
- Fix them together, with a cylinder screwdriver 8 mm, and tighten it (torque, 4 N·m).

## 6.4. Data Cable Connection

### ▲ QUALIFIED PERSON

#### 6.4.1. Data Cable Connection between Inverter and BMU

Additionally required mounting material (not included in the scope of delivery):

One data cable

**Data cable requirements:**

The cable length and quality affect the quality of the signal. Observe the following cable requirements.

- Cable category: Cat5, Cat5e or higher
- Plug type: Metal Shielded RJ45 of Cat5, Cat5e or higher
- Shielding: Yes
- UV-resistant for outdoor use
- Straight- through wired cables

Maximum cable length: 20 m.

**Procedure:**

1. Read the designation of the INVERTER port on BMU and the inverter manual, and decide whether to modify the data cable.

The designation of INVERTER port on BMU could be read below.

No.	Assignment
1	Unused
2	Unused
3	Unused
4	CAN H
5	CAN L
6	Unused
7	Unused
8	Unused

Our compatible inverters' communication ports with BMU designation could be read in table above.

The detailed connection instruction with different inverters could be read in the Appendix.

**Note:** the information here is just for reference. If it is contrary to the inverter manufacture's manual, take the later one into account.

If the data cable has to be modified, please cut the cable, arrange the wire positions, and crimp the RJ45 connector with a network wire clamp.

2. Plug RJ 45 connector to the “Inverter” port of BMU, and the other side to the corresponding port of the inverter.

### 6.4.2. Data Cable Connection between BMU and a battery module

#### Procedure:

1. Plug one side of the RJ45 connector to the “BMS” port of BMU.
2. Plug the other RJ45 connector to the “IN” port of BMS.

### 6.4.3. Data Cable Connection between battery modules

#### Procedure:

1. Get rid of the terminal resistor at the “OUT” port of the battery module in which the “IN” port has been occupied.
2. Plug one side of the RJ45 connector to the “OUT” port.
3. Plug the other RJ45 connector to the “IN” port of another battery module.
4. Keep the terminal resistor at the last module “OUT” port there.

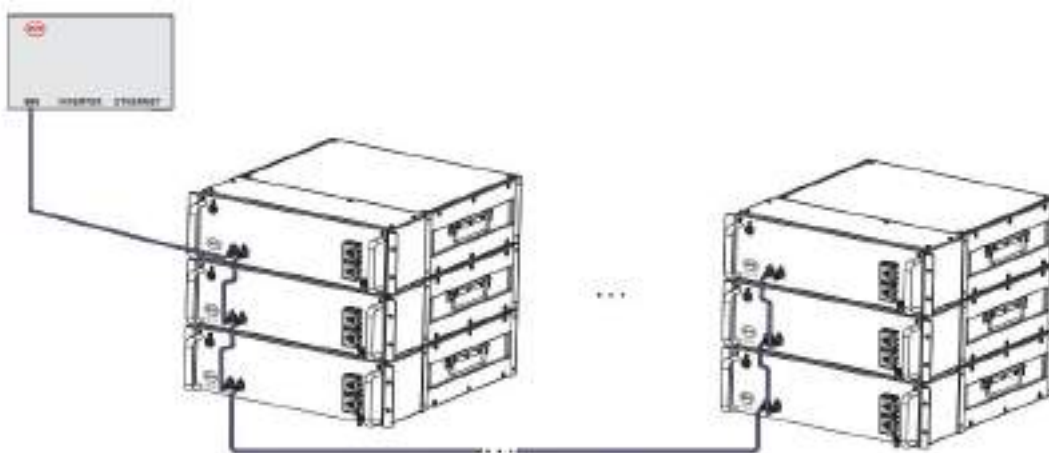

#### 6.4.4. Data Cable Connection between BMU and Router

Additionally required mounting material (not included in the scope of delivery):

One data cable

**Data cable requirements:**

The cable length and quality affect the quality of the signal. Observe the following cable requirements.

- Cable category: Cat5, Cat5e or higher
- Plug type: Metal Shielded RJ45 of Cat5, Cat5e or higher
- Shielding: Yes
- UV-resistant for outdoor use
- Straight- through wired cables
- Maximum cable length: 20 m.

**Procedure:**

1. Plug the RJ45 connector to the “Ethernet” port of BMU.
2. Plug the RJ45 connector at the other side of the cable to a router port.

**Note:** Connecting to the Internet is not compulsory but highly recommended.

#### 6.5. DC Connection

**⚠ QUALIFIED PERSON**

Additionally required mounting material (not included in the scope of delivery):

Two DC power cables for each module

**Cable requirements:**

- Conductor cross-section: 16mm<sup>2</sup>
- Maximum cable length: 20m.
- The overall cable length between the module and inverters should be approximately the same.

**Procedure**

1. Open the cover of the DC connection port.
2. Get the bolts out.

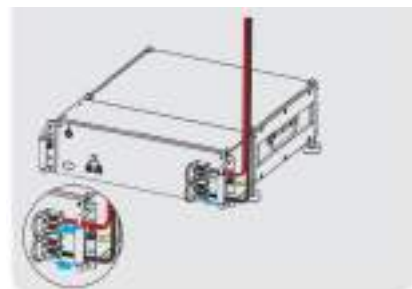

3. Lead the terminals of the DC cable there.
4. Tighten the bolts. (torque,  $6\pm 1$  N·m)
5. Close the cover of cable terminals.

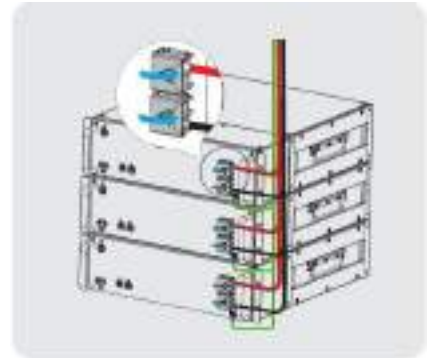

6. Seal the cover with plastic rivets.

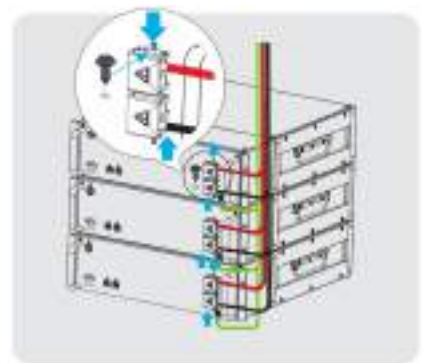

## 7. Commissioning

### 7.1. Switch on the Battery System

#### ⚠ QUALIFIED PERSON

#### Requirements:

- The power cable connection between the battery system and the inverter is switched off.
- The inverter must be correctly mounted.
- All cables must be correctly connected.

#### Procedure:

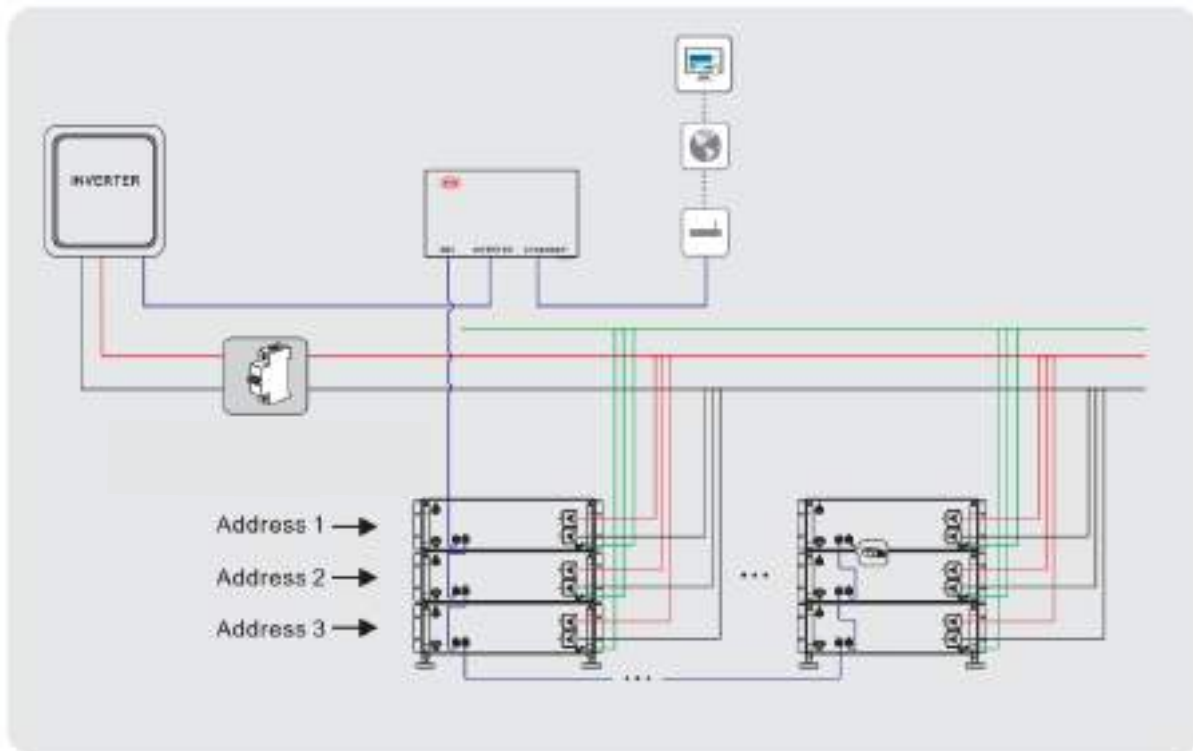

1. Switch on the air switch between the battery and inverter if there is any.
2. Press the LED button on the top of the first battery module. The LED starts to flash 0.5s white and 0.5s blue alternatively. On the condition that the BMU is well connected, it will change to solid white or blinking white later. For other cases, please refer to Chapter 11.

### 7.2. Configure the Battery System

#### ⚠ QUALIFIED PERSON

#### Procedure:

1. Download Be Connect from Google Play or App Store. The battery system requires the latest version firmware to operate. So please make sure you either have downloaded the latest firmware in your device (cell phone, Ipad, etc.), or your device could access the Internet during configuration.

2. Tick the box in front of “I agree to the Privacy Policy”, and then press the “Start” button.

3. The app will check the firmware, and download if needed if Internet is available. If there is no Internet available, you can press “Skip” to skip the firmware check.

4. After the firmware downloaded, press the button “Check WIFI Settings” to connect the battery WIFI, which begins with “BYD-” , and the full name could be found at the BMU labels.

5. Choose “Yes” to configure the battery system. And then press the “Next” button to confirm the time.

6. Choose the inverter brand that the battery system is operated together.



7. Choose “LV Flex/LV Flex Lite”, and then choose the number that how many battery modules are connected in parallel.

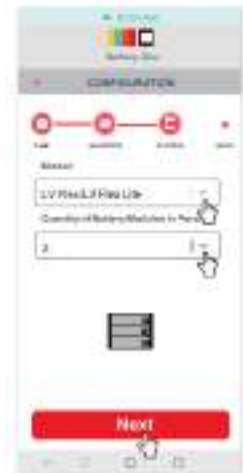

8. Choose the Application and Phase options according to the actual application.



9. Check the summary of the configuration information, tick the sentence, and press the button “Next”.



Restart the Be Connect if it was stuck somewhere.

Please note that the SOC of the battery may not be accurate before a full charge or discharge after the configuration.

### 7.3. Switch on and Commission the Inverter

#### **⚠ QUALIFIED PERSON**

##### **Procedure:**

1. Mount and connect the inverter according to the inverter manufacturer`s instruction.
2. Commission and configure the inverter according to the inverter manufacturer`s instruction.

If the battery information could be read correctly, it means the connection between the battery system and the inverter is all right. Normally, the LED of the BMU will also turn to white then, and the battery system is ready to work.

If LED of BMU still flashes blue, and/or there are some battery errors shown at the inverter, go to the Chapter 11 of this manual.

## 8. Operation

### 8.1. Switch on the Battery System

To make sure the battery system can work well with the inverter, please follow the right procedure to start them.

The procedure is:

- 1) turn on the switch between the inverter and battery if there is any;
- 2) switch on the battery system;
- 3) switch on the inverter.

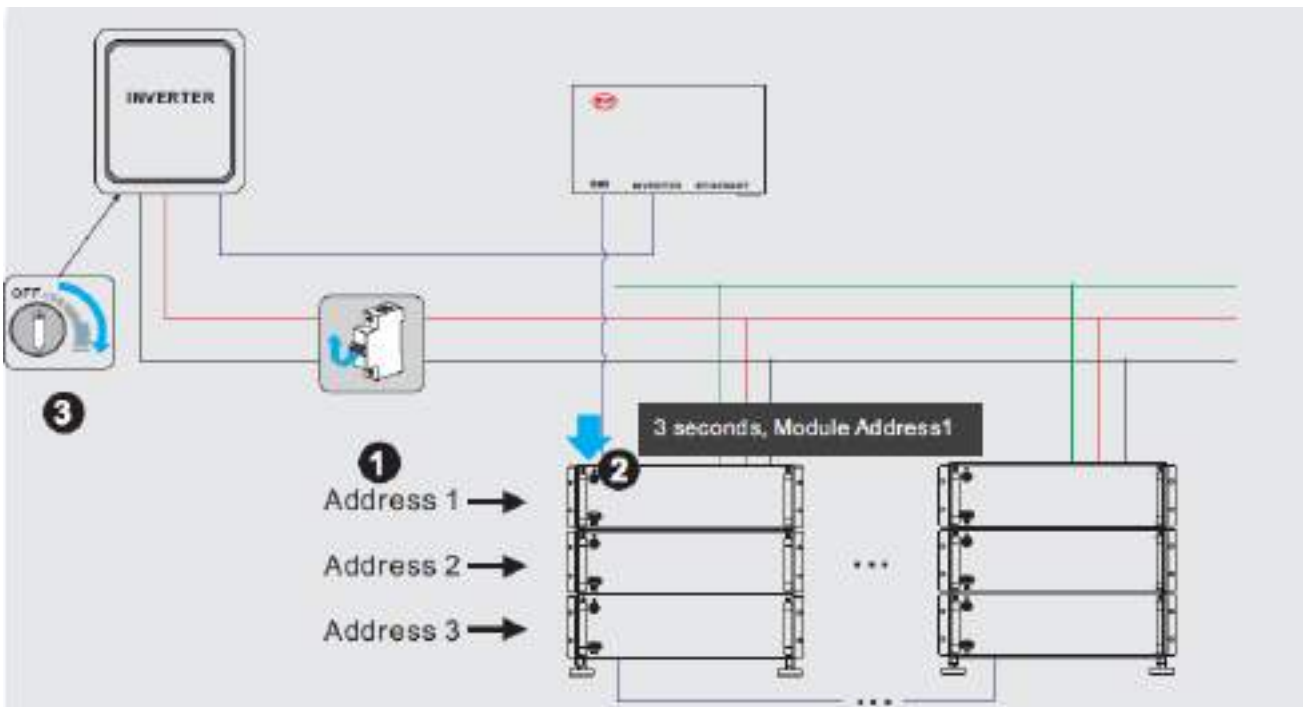

## 8.2. Switch off the Battery System

The procedure to switch off the battery system is: 1) switch off the inverter; 2) switch off the battery; 3) switch off the air switch between the battery and the inverter if there is any.

The way to switch off the battery system is to press the LED Button on the BMU for 5 seconds.

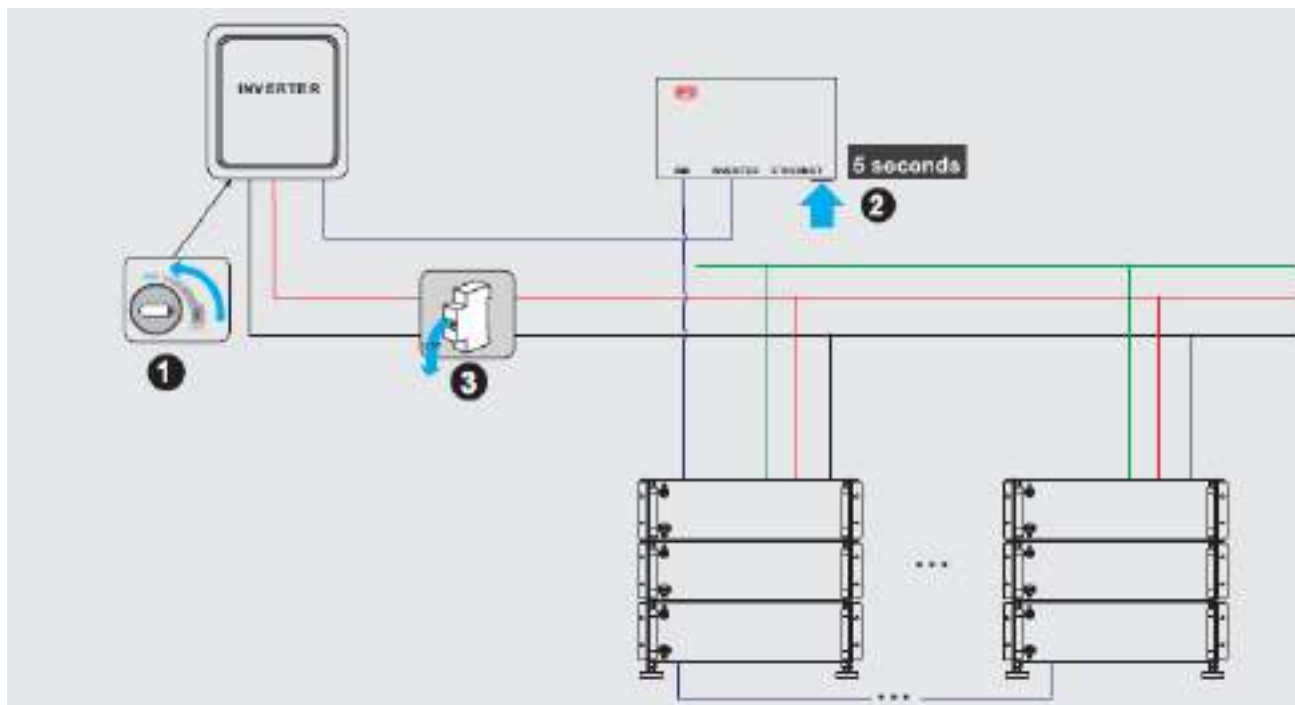

## 9. Decommissioning

 **QUALIFIED PERSON**

 **CAUTION**

### Risk of injury due to weight of the battery module

Injuries may result if the battery module is lifted incorrectly or dropped while being transported or installed.

- Transport and lift the battery module carefully. Take the weight of the battery module into account.
- Wear suitable personal protective equipment for all work on the battery system.

### Procedure:

1. Shut off the inverter.
2. Switch off the battery system.
3. Switch off the breaker between the inverter and the battery system if there is any.
4. Disconnect the DC cables between inverter and the battery system, PE, and data cable among battery system, inverter, BMU and router (if applicable).
5. Loose the screws between battery modules.

If the battery system is to be stored or shipped, pack the system. Use the original packaging or packaging that is suitable for the weight and dimensions of the system.

Dispose of the battery system in accordance with the locally applicable disposal regulations for electronic waste.

## 10. Extension

The battery system could be extended at any time.

**Procedure:**

1. Shut off the inverter.
2. Switch off the battery system.
3. Switch off the breaker between the inverter and the battery system if there is any.
4. Add the new module on top of other battery modules.
5. Switch on the breaker between the inverter and the battery system if there is any.
6. Switch on and configure the battery system.
7. Start the inverter.

## 11. Troubleshooting

### 11.1. Battery System Behavior under Fault Conditions

#### Blue light flashing

If blue LED flashes, and the interval time between two flashes is 1 second, which means an error happened. (When the system is initiating, the white light and blue light flash alternatively every 0.5s. That is not an error.)

The detailed designation for errors of each LED lights could be read in 11.2.

Except the LED light, we can also get the faulty messages of the battery through the remote server and Be Connect Plus. Information read through that could help a lot to identify the issues. So highly recommend to connect the battery system to the Internet or download and use Be Connect Plus.

#### WLAN is not available

Contact with BYD local after-sales service.

#### The battery system is not able to be turned on.

Check the system has been constructed according to the Battery-Box Premium Compatible Inverter List. If the problem still cannot be solved, contact with BYD local after-sales service within 48 hours.

### NOTICE

#### Damage to the battery system due to under voltages

- If the battery system doesn't start at all, please contact BYD local after-sales service within 48 hours. Otherwise, the battery could be permanently damaged.

#### The battery system cannot be turned off.

Contact with BYD local after-sales service.

#### BMU cannot be powered on.

Contact with BYD local after-sales service.

### 11.2. LED Light Designation for Errors

#### LED light on BMU

Blue LED is flashing one time.	System initiating failed
Blue LED is flashing two times.	Address distribution failed
Blue LED is flashing three times.	Precharge failed
Blue LED is flashing for four times.	BMS failure
Blue LED is flashing five times.	BMS and BMU communication failed
Blue LED is flashing six times.	Communication with an inverter failed
Blue LED is flashing seven times.	Configuration not correct

**LED light on battery**

Blue LED is flashing once	DC cable connection incorrect
Blue LED is flashing two times	MOS faulty
Blue LED is flashing three times	BIC (battery information collector) communication failed
Blue LED is flashing four times	Battery sensor faulty
Blue LED is flashing five times	Volt sensor faulty
Blue LED is flashing six times	Current sensor faulty
Blue LED is flashing seven times	Battery faulty
Blue LED is flashing eight times	Precharge failed
Blue LED is flashing nine times	BIC balance failed
Blue LED is flashing ten times	Temperature sensor on battery control unit faulty
Blue LED is flashing eleven times	BMS and BMU communication failure

## 12. Maintenance and Storage

### Cleaning

It is recommended that the battery system be cleaned periodically. If the enclosure is dirty, please use a soft, dry brush or a dust collector to remove the dust. Liquids such as solvents, abrasives, or corrosive liquids should not be used to clean the enclosure.

### Maintenance

The battery module should be stored in an environment with a temperature range between  $-10^{\circ}\text{C}$  ~  $+50^{\circ}\text{C}$ , and charged regularly according to the table below with no more than 0.5 C (A C-rate is a measure of the rate at which a battery is discharged relative to its maximum capacity. ) to the SOC of 40% after a long time of storage.

Storage environment temperature	Relative humidity of the storage environment	Storage time	SOC
Below $-10^{\circ}\text{C}$	/	Not allowed	/
$-10\sim 25^{\circ}\text{C}$	5%~70%	$\leq 12$ months	$25\%\leq\text{SOC}\leq 60\%$
$25\sim 35^{\circ}\text{C}$	5%~70%	$\leq 6$ months	$25\%\leq\text{SOC}\leq 60\%$
$35\sim 50^{\circ}\text{C}$	5%~70%	$\leq 3$ months	$25\%\leq\text{SOC}\leq 60\%$
Above $50^{\circ}\text{C}$	/	Not allowed	/

### NOTICE

#### Damage to the battery system due to under voltages

- If the battery system doesn't start at all, please contact BYD local after-sales service within 48 hours. Otherwise, the battery could be permanently damaged.

## 13. Disposal of the Battery System

Disposal of the system must comply with the local applicable disposal regulations for electronic waste and used batteries.

- Do not dispose of the battery system with your household waste.
- Avoid exposing the batteries to high temperatures or direct sunlight.
- Avoid exposing the batteries to high humidity or corrosive atmospheres.
- For more information, please contact BYD.

## 14. Technical Parameters

Usable Energy [1]	5.0 kWh
Max Cont. Output Current [2]	70 A
Peak Output Current [2]	105 A, 5 s
Dimensions (H/W/D)	132x 482 x 510 mm
Weight	47 kg
Nominal Voltage	51.2 V
Operating Voltage	43.2 -57.6 V
Operating Temperature	-10 °C to +50°C
Battery Cell Technology	Lithium Iron Phosphate (cobalt-free)
Communication	CAN
Enclosure Protection Rating	IP20
Round-trip Efficiency	≥95%
Scalability	Max. 64 in Parallel (320 kWh)
Certification	IEC62619 / CE / UN38.3 / IEC62040
Applications	ON Grid / ON Grid + Backup / OFF Grid
Compatible Inverters	Refer to BYD Battery-Box LV Flex Lite Minimum C
Nominal Capacity	100 Ah
DOD	100%
Short Circuit Current $\square$	2500 A
Max Output Power	5.4 kW
Battery Designation	IFpP/50/160/119/(16S)M/-10+40/90

[1] DC Usable Energy, Test conditions: 100% DOD, 0.2C charge & discharge at + 25 °C. System usable energy may vary due to system configuration parameters.

[2] Charge derating will occur between -10 °C and +5 °C.

## 15. Contact Information

### BYD Global Service

bboxservice@byd.com

Telephone: +86 755 89888888-47175

Address: No.3009, BYD Road,  
Pingshan, Shenzhen, 518118, P.R. China

www.bydbatterybox.com

Social media link

<https://www.facebook.com/BatteryBoxBYD/>

[https://twitter.com/BYD\\_BatteryBox](https://twitter.com/BYD_BatteryBox)

<https://www.linkedin.com/company/byd-battery-box>

### Australia

Alps Power Pty Ltd

service@alpspower.com.au

Telephone: +61 2 8005 6688

Address: 14/47-51 Lorraine St  
Peakhurst NSW 221

www.alpspower.com.au

### Europe

EFT-Systems GmbH

service@eft-systems.de

Telephone +49 9352 8523999

+44 (0) 2037695998(UK)

+34 91 060 22 67(ES)

+39 02 87368364(IT)

Address: Bruchtannenstraße 28, 63801  
Kleinostheim, Germany

www.eft-systems.de

### South Africa

AFRIPLUS ENERGY GROUP (PTY)  
LTD

Support@afriplusenergy.co.za

Telephone: +27 21 140 3594

Address: The Pavilion, Corner of  
Dock & Portwood Road, V&A  
WATERFRONT, 8001, CAPE TOWN

### LATAM

BYD LATAM Service

bboxservLATgrp@byd.com

# Appendix Data Cable Connection Instruction with Inverters

